

DO NOT SCALE THE DRAWING

ALL DIMENSIONS IN MM

REMOVE SHARP EDGES

IF IN DOUBT ASK

REFER MEDIUM IS:2102 FOR UNSPECIFIED ANGULAR AND ALIGNMENT DEVIATIONS

REV. NO.

DATE

BRIEF RECORD

NAME

①

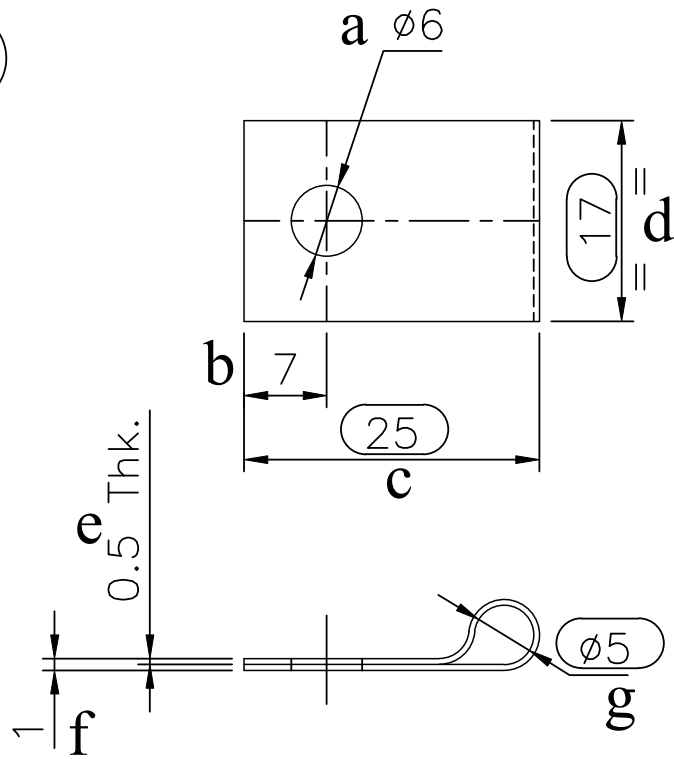

②

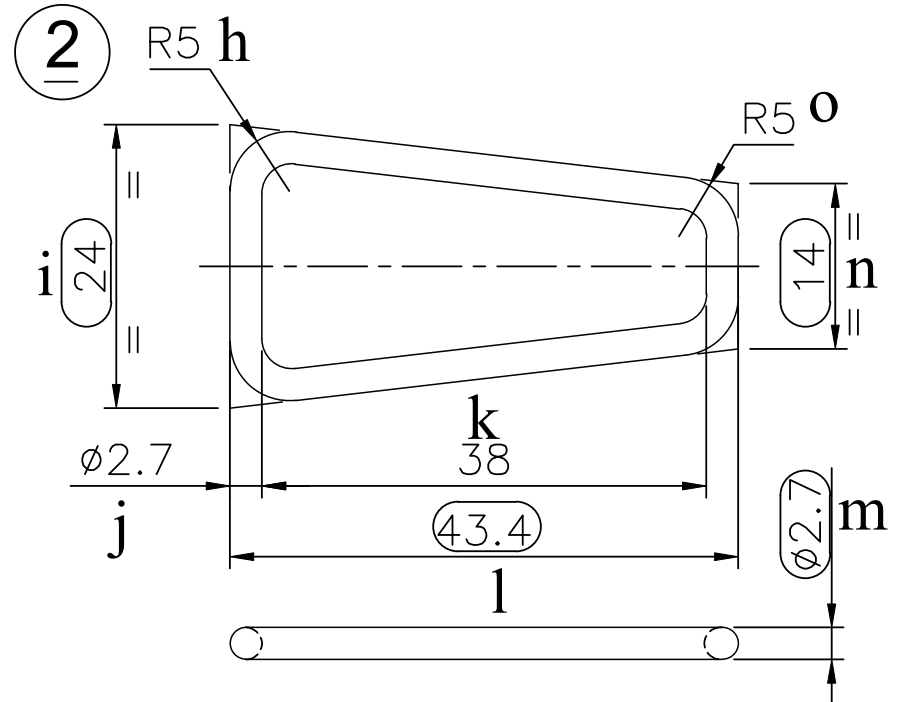

DETAILS

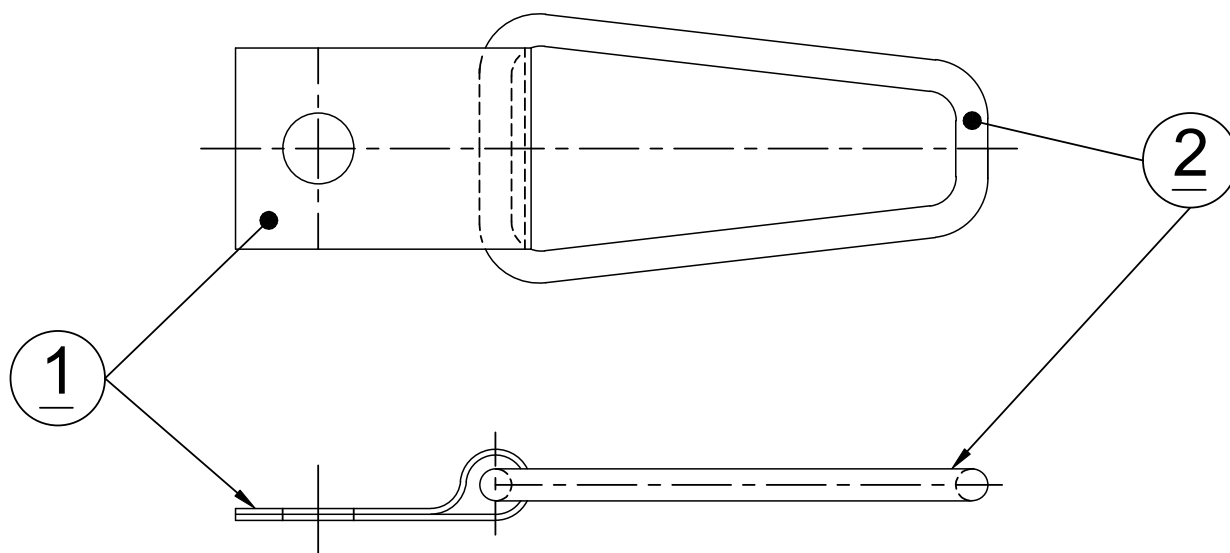

ASSEMBLY

NOTES ;

- UNLESS OTHERWISE SPECIFIED
* CORNERS SHOWN SHARP 0.5 PERMISSIBLE
- FORMED PART SHOULD BE FREE FROM CRACKES,STRETCH MARKS,RIPPLES & OTHER IMPERFECTIONS
- ALL DRILLED/PUNCHED HOLES SHOULD BE FREE FROM SHARP EDGES,BURRS & CLEANED PROPERLY
- FIRST SAMPLE SHOULD BE APPROVED BY C.D.T.S. REAY ROAD
- NO. REQD. PER UNIT = ONE , WEIGHT = (6.0 Gms.)
- DIMENSIONS ARE ENCLOSED WITH THIS BOX TO BE MENTIONED IN QAP.

LEGENDS	SPECIFICATIONS	TOLERANCES
a	6.0	±0.1
b	7.0	±0.2
c	25.0	±0.2
d	17.0	±0.2
e	0.5 Thk.	±0.1
f	1.0	±0.1
g	5.0	±0.1

LEGENDS	SPECIFICATIONS	TOLERANCES
h	5.0	±0.1
i	24.0	±0.2
j	2.7	±0.1
k	38.0	±0.3
l	43.4	±0.3
m	2.7	±0.1
n	14.0	±0.2
o	5.0	±0.1



Bajaj Electricals Limited

PRODUCT 1516-10

NAME

DATE

MATERIAL

MS

RANGE OF NOMINAL DIMENSIONS

DESIGNED

-

-

ABOVE

0.5

3.0

6.0

30

120

315

DRAWN

SHAILESH

06/01/16

FINISH

UPTO

3.0

6.0

30

120

315

1000

CHECKED

SAN

06/01/16

DEVIATION

±0.1

±0.1

±0.2

±0.3

±0.5

±0.8

APPROVED

MANINATH

06/01/16

SCALE

1:1

HANDLE LOOP DETAILS & ASSY

DRG.NO.

1516-10/0005

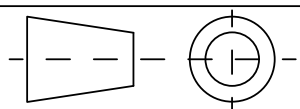

USED ON :FOR ALL MODELS OF PRESSURE COOKER

SHEET OF

A4