



EMDET ENGINEERS PVT. LTD.
 PLOT NO. 30,1/A HSIIDC
 INDUSTRIAL AREA DHARUHERA
 REWARI-123106,HARYANA

QUALITY ASSURANCE
 SPECIFICATION-FRAME

DOC NO.: ENG-EE-QA-O-05W-09WIA70-2
 ISSUE: 01
 REVISION: 00
 DATE: 20.01.2021

ITEM IMAGE

- 1 **ITEM** A70- FRAME WITH RING $\varnothing 70 \pm 0.5 * H83 \text{mm}$; NECK ID -20mm
- 2 **cSKU** EP01033



3 SPECIFICATION

SR.NO	PARAMETER	MEASURING INSTRUMENT	SPECIFICATION
1	FRAME HEIGHT(mm)	DIGITAL HEIGHT GAUGE	69.70±0.30
2	FRAME DIAMETER 1 (mm)	DIGITAL CALIPER	67.50±0.30
3	FRAME INNER DIA (mm)	DIGITAL CALIPER	64.00±0.30
4	FRAME DIAMETER 2 (mm)	DIGITAL CALIPER	25.20±0.10
5	RING HEIGHT (mm)	DIGITAL HEIGHT GAUGE	12.2±0.10
6	RING OUTER DIAMETER (mm)	DIGITAL CALIPER	70±0.30
7	RING INNER DIA 1 (mm)	DIGITAL CALIPER	67.1±0.30
8	RING INNER DIA 2 (mm)	DIGITAL CALIPER	36.4±0.10
9	RING DEPTH (mm)	DIGITAL CALIPER	2.4±0.10

4 APPEARANCE / FINISH :-

- A) Material Should Be Scratch Free
- B) Material Should Be Burr Free
- C) Material Should Not Be Damaged.
- D) Material Should Be Scratch Free

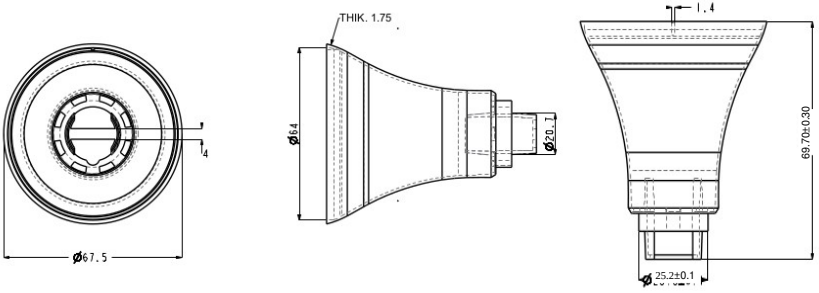

5 ACCEPTANCE CRITERIA:-

- A) Consignment To Be Accompanied With Manufacturer's Test Certificate.
- B) Based On Receiving Inspections.
- C) Should Be Approved Make.

6 PACKING REQUIREMENTS:-

- A) Material Should Be Standard Packaging;
- B) Material Should Be Pack In Proper way And Inside The Master Carton.
- C) Material Should Be Received In Standard Qty. In Each Box.
- D) Material Should Not Be In Damage Condition.
- E) Marking Requirement On The Master Carton:
 - I Item Description & Value
 - II Item Code
 - III Po No.
 - IV Quantity
 - V Net Weight / Gross Weight

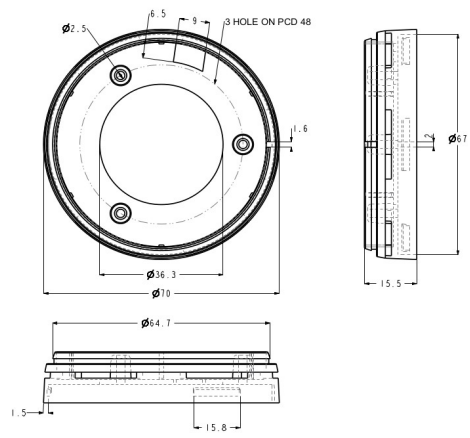

Anas Mushtaq

PREPARED BY:- ANAS MUSHTAQ

Alok Pandey

CHECKED BY:- ALOK PANDEY

S. Kant

APPROVED BY:- SHASHIKANT KUMAR

REVISION HISTORY

Sr. No.	Rev. No.	Rev. Date	Revision Description